



Myers[®]
ENGINEERED PRODUCTS

4RC and 4RCX

4" NON-CLOG WASTEWATER PUMPS

Standard (4RC) and Explosion-Proof (4RCX) Construction



3450 RPM



1150 & 1750 RPM



APPROVED
(4RCX only)

THE RIGHT CHOICE

The 4RC and 4RCX (explosion-proof) submersible wastewater pumps are the right choice when difficult to pump fibrous or stringy solids are to be expected. The 4RC/4RCX series provides smooth, vibration-free operation when operating at heads higher than peak efficiency. The pump is for use in municipal lift stations, treatment plants and industrial waste water applications.

Myers offers a complete line of wastewater pumps, lift-out rail assemblies, controls and accessories to meet your needs. Call your Myers distributor or the Myers sales office at 419-289-1144 for more details.

Passes stringy trash, fibrous wastes, slurries, and other difficult to pump solids that standard enclosed or semi-open impellers cannot.

- Recessed impeller design has completely open passage in volute.
- Pumping action is by vortex; solids can't get caught in impeller volute.
- Operates without vibration or cavitation over entire performance curve. Operates near shutoff without harming pump.

Durable motor will deliver many years of reliable service.

- Recessed impeller greatly increases bearing life by reducing radial load.
- Oil-filled motor for maximum heat dissipation and constant bearing lubrication.
- Heat sensor thermostats imbedded in windings protect motor from overheat conditions.
- Seal leak probes warn of moisture entry; helps prevent costly motor burnout.

AVAILABLE WITH OPTIONAL FM APPROVAL FOR USE IN CLASS 1, GROUPS C AND D HAZARDOUS LOCATIONS (4RCX ONLY).



Product Capabilities

Capacities To	1250 gpm	78.8 lps
Heads To	265 ft.	80.8 m
Solids Handling	3 in.	76 mm
Liquids Handling	Raw unscreened sewage, fibrous wastewater, effluent, storm water	
Intermittent Liquid Temp.	up to 140°F	up to 60°C
Winding Insulation Temp. (Class H)	356°F	180°C
Motor Electrical Data	1150 rpm 3–15 HP, 200/230/460/575V, 3 phase, 60 Hz 1750 rpm 10–40 HP, 200/230/460/575V, 3 phase, 60 Hz 3450 rpm 20–60 HP, 230/460/575 volts, 3 phase, 60 Hz	
Third Party Approvals	FM, Class 1, Div. 1, Groups C & D (4RCX only)	
Acceptable pH Range	6–9	
Specific Gravity	.9–1.1	
Viscosity	28 – 35 SSU	
Discharge, Horizontal	4 in.	101.6 mm
Flanged Centerline	125 lb. ANSI	

NOTE: Consult factory for applications outside of these recommendations.

Construction Materials

Motor Housing, Seal Housing, Cord Cap and Volute Case	Cast iron, Class 30, ASTM A48
Recessed, Impeller	Ductile iron, Class 65, ASTM A536
Power and Control Cord	35 ft. SOOW
Mechanical Seals	Double tandem, type 21
	Standard Optional
	Carbon and ceramic Lower tungsten carbide, silicon carbide
Pump, Motor Shaft	416 SST
Fasteners	300 series SST

ADVANTAGES BY DESIGN

POWER & CONTROL CORDS

SOOW, FM and CSA approved oil-resistant cable.

CABLE ENTRY SYSTEM

Provides triple seal protection. Cable jacket sealed by compression grommet. Individual wires sealed by epoxy potting. Terminal board separates motor chamber from cord cap.

BALL BEARINGS

Upper and lower ball bearings support shaft and rotor and take axial and radial loads.

HEAT SENSOR

Protects motor from burnout due to excessive heat from any overload condition. Automatically resets when motor has cooled.

MOTOR STATOR

Heat shrunk into housing for perfect alignment and best heat transfer. Oil-filled motor conducts heat and lubricates bearings.

SHAFT SEALS

Double tandem mechanical shaft seals protect motor. Oil-filled seal chamber provides continuous lubrication.

HEAVY 416 SST SHAFT

Corrosion resistant.

SEAL LEAK PROBES

Detect water in seal housing. Activate warning light in control panel.

SLEEVE BEARING

Takes radial shock load; provides flame path.

RECESSED IMPELLER

Handles stringy trash and slurries without clogging or binding. Pump-out vanes help keep trash from seal; reduces pressure at seal faces.

VOLUTE CASE

Handles 3" solids. Completely open from inlet to discharge. 4" ANSI 125 lb. flange.

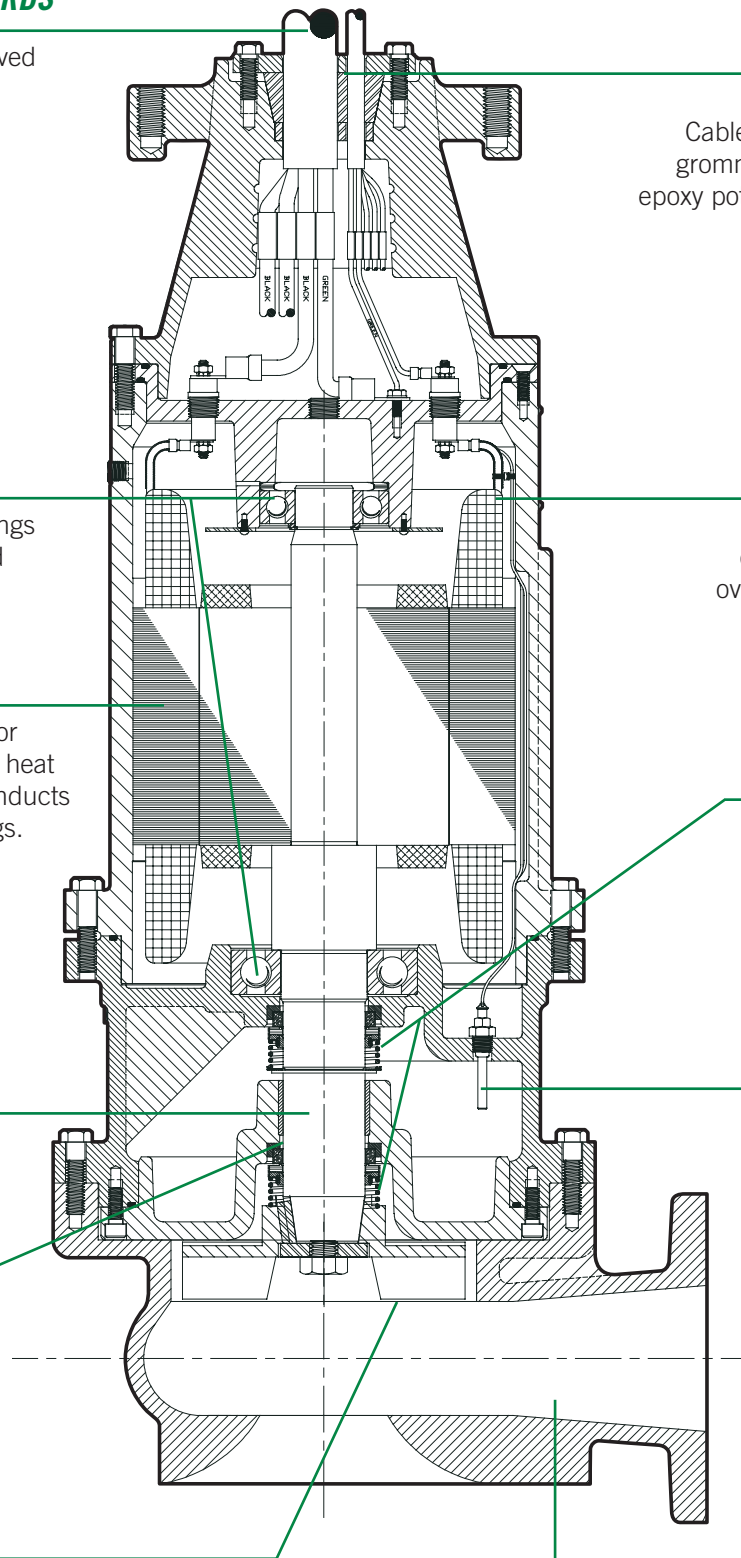

3450 RPM

1150 & 1750 RPM

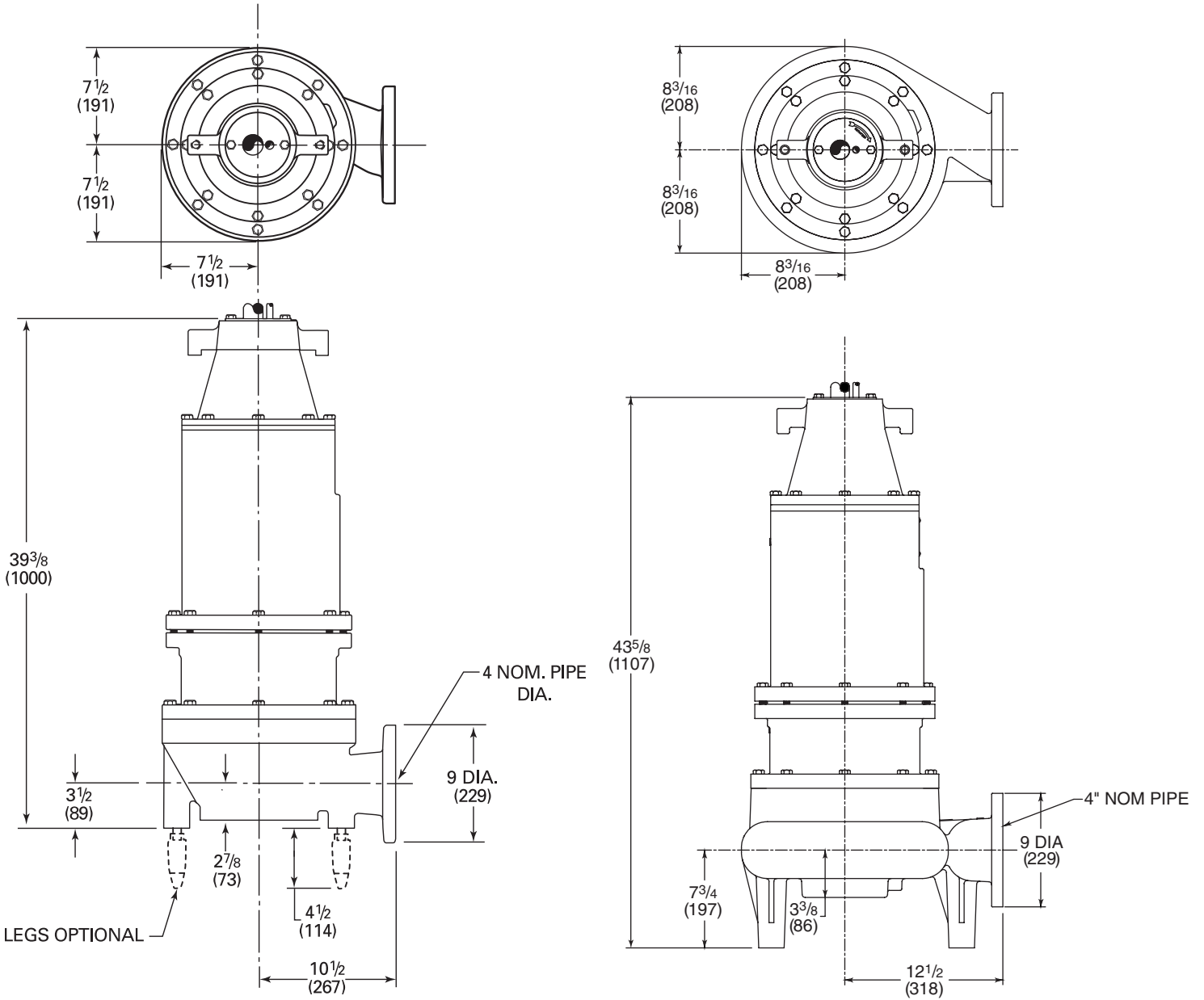

Dimensions in inches
() Dimensions in mm

1150 RPM PERFORMANCE CURVE

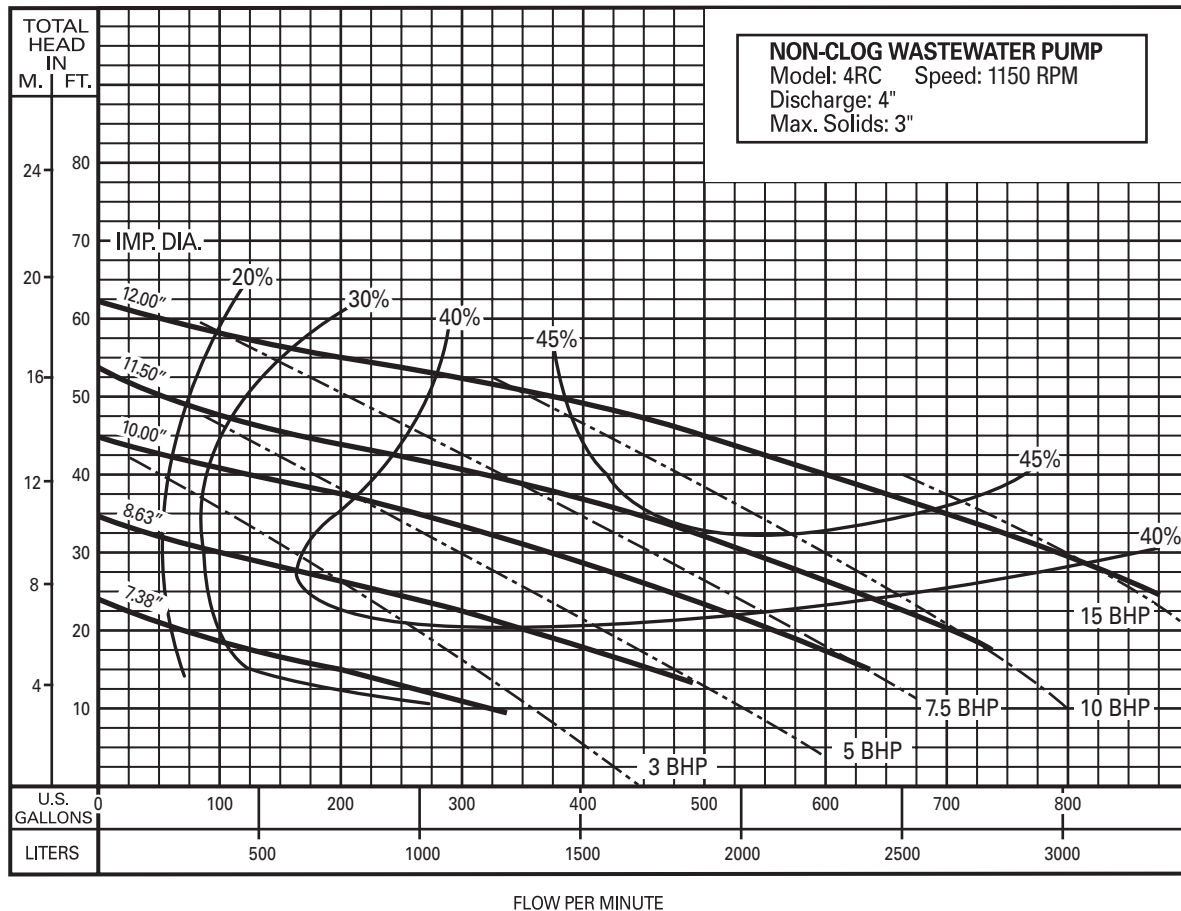

Available Models		Motor Electrical Data												
Standard	Explosion Proof	HP	Volts	Phase	Hertz	Start Amps	Run Amps	Service Factor Amps	Run KW	Service Factor KW	Start KVA	Run KVA	NEC Code Letter	Service Factor
4RC30M6-03	4RCX30M6-03	3	200	3	60	106	13.3	15.6	3.4	4.1	36.7	4.6	K	1.2
4RC30M6-23	4RCX30M6-23	3	230	3	60	92	11.6	13.6	3.4	4.1	36.7	4.6	K	1.2
4RC30M6-43	4RCX30M6-43	3	460	3	60	46	5.8	6.8	3.4	4.1	36.7	4.6	K	1.2
4RC30M6-53	4RCX30M6-53	3	575	3	60	36.8	4.6	5.4	3.4	4.1	36.7	4.6	K	1.2
4RC50M6-03	4RCX50M6-03	5	200	3	60	106	19.3	23	4.8	5.8	36.7	6.7	J	1.2
4RC50M6-23	4RCX50M6-23	5	230	3	60	92	16.8	20	4.8	5.8	36.7	6.7	J	1.2
4RC50M6-43	4RCX50M6-43	5	460	3	60	46	8.4	10	4.8	5.8	36.7	6.7	J	1.2
4RC50M6-53	4RCX50M6-53	5	575	3	60	37	6.7	8	4.8	5.8	36.7	6.7	J	1.2
4RC75M6-03	4RCX75M6-03	7.5	200	3	60	197	27	32.2	6.8	8.4	68.5	9.4	H	1.2
4RC75M6-23	4RCX75M6-23	7.5	230	3	60	172	23.6	28	6.8	8.4	68.5	9.4	H	1.2
4RC75M6-43	4RCX75M6-43	7.5	460	3	60	86	11.8	14	6.8	8.4	68.5	9.4	H	1.2
4RC75M6-53	4RCX75M6-53	7.5	575	3	60	69	9.4	11.2	6.8	8.4	68.5	9.4	H	1.2
4RC100M6-03	4RCX100M6-03	10	200	3	60	197	34.3	41.4	8.8	10.9	68.5	12.0	H	1.2
4RC100M6-23	4RCX100M6-23	10	230	3	60	172	30	36	8.8	10.9	68.5	12.0	H	1.2
4RC100M6-43	4RCX100M6-43	10	460	3	60	86	15	18	8.8	10.9	68.5	12.0	H	1.2
4RC100M6-53	4RCX100M6-53	10	575	3	60	69	12	14.4	8.8	10.9	68.5	12.0	H	1.2
4RC150M6-03	4RCX150M6-03	15	200	3	60	276	48	59.8	13.0	15.7	95.6	17.5	H	1.2
4RC150M6-23	4RCX150M6-23	15	230	3	60	240	44	52	13.0	15.7	95.6	17.5	H	1.2
4RC150M6-43	4RCX150M6-43	15	460	3	60	120	22	26	13.0	15.7	95.6	17.5	H	1.2
4RC150M6-53	4RCX150M6-53	15	575	3	60	96	17.6	20.8	13.0	15.7	95.6	17.5	H	1.2

Motor Efficiencies and Power Factor									
		Motor Efficiency %				Power Factor %			
HP	Phase	Service Factor Load	100% Load	75% Load	50% Load	Service Factor Load	100% Load	75% Load	50% Load
3	3	69	66	60	51	72	74	63	55
5	3	82	81	77	68	74	72	66	56
7.5	3	84	83	79	71	75	73	66.5	56.5
10	3	87	86	82	75	76	74	67	57
15	3	88	88	86.5	82.5	76	74.5	68	57.5

1750 RPM PERFORMANCE CURVE

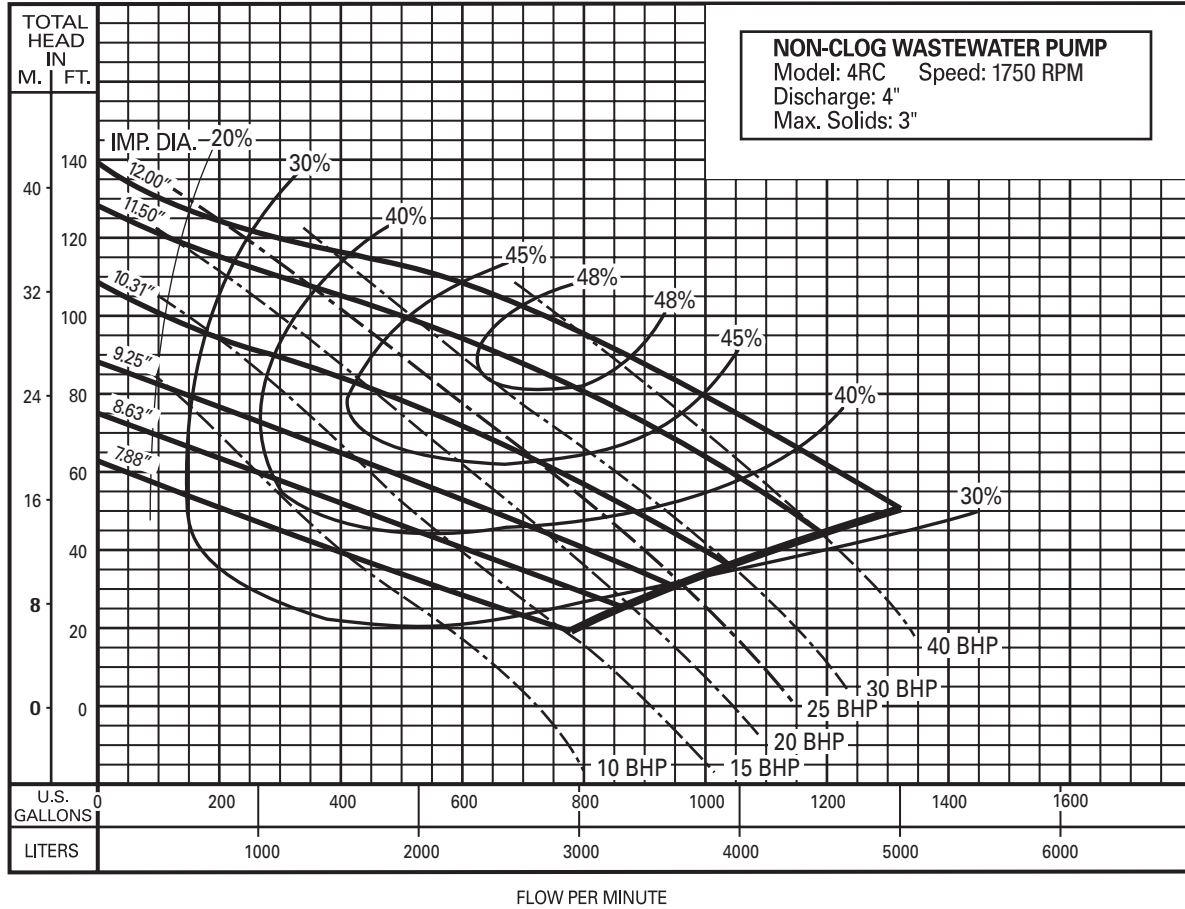

Available Models		Motor Electrical Data												
Standard	Explosion Proof	HP	Volts	Phase	Hertz	Start Amps	Run Amps	Service Factor Amps	Run KW	Service Factor KW	Start KVA	Run KVA	NEC Code Letter	Service Factor
4RC100M4-03	4RCX100M4-03	10	200	3	60	334	35.9	40.6	9.5	11.4	116	12.4	N	1.2
4RC100M4-23	4RCX100M4-23	10	230	3	60	290	31.2	35.3	9.5	11.4	116	12.4	N	1.2
4RC100M4-43	4RCX100M4-43	10	460	3	60	145	15.6	17.7	9.5	11.4	116	12.4	N	1.2
4RC100M4-53	4RCX100M4-53	10	575	3	60	116	12.5	14.1	9.5	11.4	116	12.4	N	1.2
4RC150M4-03	4RCX150M4-03	15	200	3	60	334	50.6	61	15.0	18.6	115.5	17.5	E	1.2
4RC150M4-23	4RCX150M4-23	15	230	3	60	290	44	53	15.0	18.6	115.5	17.5	E	1.2
4RC150M4-43	4RCX150M4-43	15	460	3	60	145	22	26.5	15.0	18.6	115.5	17.5	E	1.2
4RC150M4-53	4RCX150M4-53	15	575	3	60	116	17.6	21.2	15.0	18.6	115.5	17.5	E	1.2
4RC200M4-03	4RCX200M4-03	20	200	3	60	334	62.5	75	21.2	26.1	115.5	23.9	G	1.2
4RC200M4-23	4RCX200M4-23	20	230	3	60	290	60	72	21.2	26.1	115.5	23.9	G	1.2
4RC200M4-43	4RCX200M4-43	20	460	3	60	145	30	36	21.2	26.1	115.5	23.9	G	1.2
4RC200M4-53	4RCX200M4-53	20	575	3	60	116	24	28.8	21.2	26.1	115.5	23.9	G	1.2
4RC250M4-03	4RCX250M4-03	25	200	3	60	575	78.3	92.2	26.9	33.3	180.1	30.3	G	1.2
4RC250M4-23	4RCX250M4-23	25	230	3	60	452	76	92	26.9	33.3	180.1	30.3	G	1.2
4RC250M4-43	4RCX250M4-43	25	460	3	60	226	38	46	26.9	33.3	180.1	30.3	G	1.2
4RC250M4-53	4RCX250M4-53	25	575	3	60	181	30.4	36.8	26.9	33.3	180.1	30.3	G	1.2
4RC300M4-03	4RCX300M4-03	30	200	3	60	575	92.2	110.7	33.3	41.3	180.1	37.4	G	1.2
4RC300M4-23	4RCX300M4-23	30	230	3	60	452	94	114	33.3	41.3	180.1	37.4	G	1.2
4RC300M4-43	4RCX300M4-43	30	460	3	60	226	47	57	33.3	41.3	180.1	37.4	G	1.2
4RC300M4-53	4RCX300M4-53	30	575	3	60	181	37.6	45.6	33.3	41.3	180.1	37.4	G	1.2
4RC400M4-43	4RCX400M4-43	40	460	3	60	290	61	74	43.2	53.0	231.1	48.6	G	1.2

Motor Efficiencies and Power Factor									
		Motor Efficiency %				Power Factor %			
HP	Phase	Service Factor Load	100% Load	75% Load	50% Load	Service Factor Load	100% Load	75% Load	50% Load
10	3	81	79	74	65	79	77	72	64
15	3	85	84	79	69	88	86	78	68
20	3	88	87.5	81	72.5	91	89	79	69
25	3	87	86	81	73	91	89	80	70
30	3	87	86	83	79	91	89	82	73
40	3	86	86	88	87.5	90	89	86	80

3450 RPM PERFORMANCE CURVE

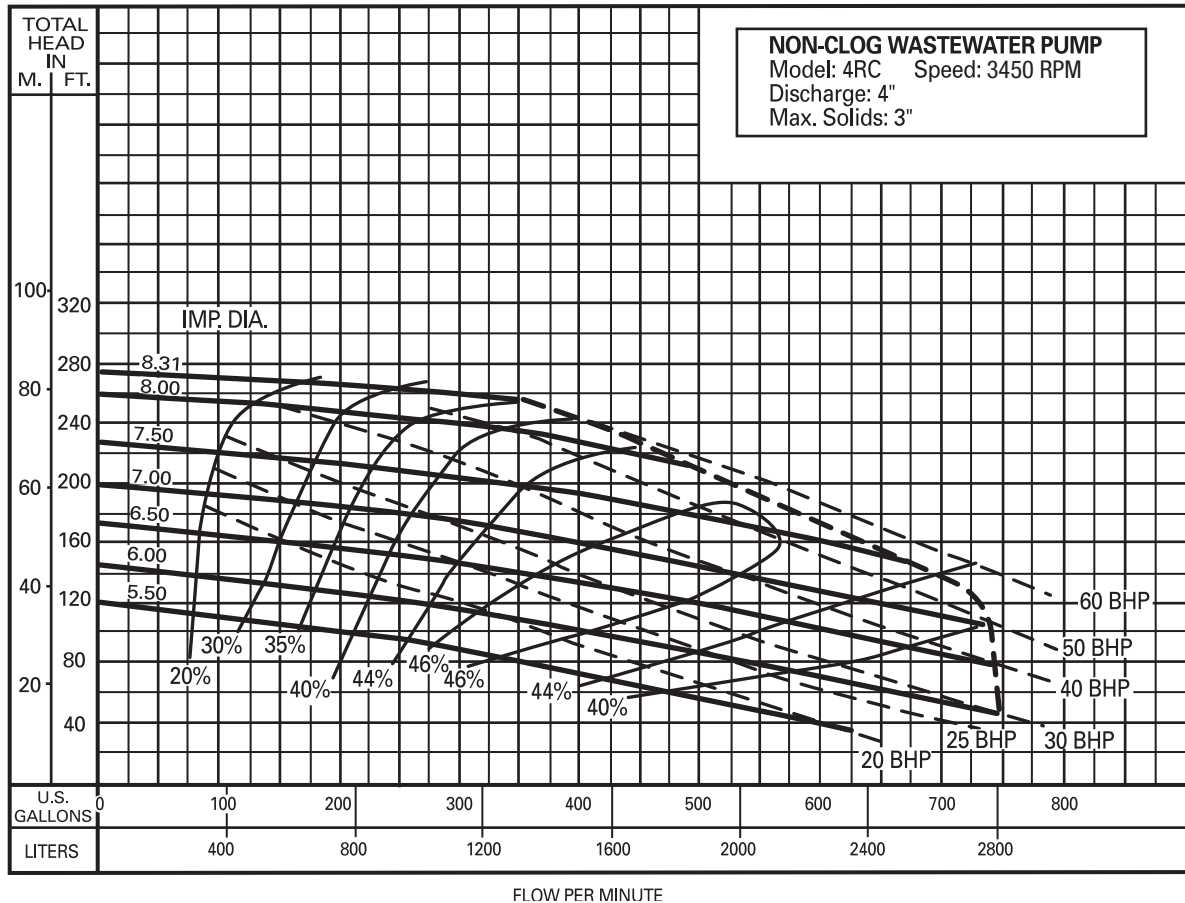

Available Models		Motor Electrical Data												
Standard	Explosion-Proof	HP	Volts	Phase	Hz	Start Amps	Run Amps	Service Factor Amps	Run KW	Service Factor KW	Start KVA	Run KVA	NEC Code Letter	Service Factor
4RC200M2-23	4RCX200M2-23	20	230	3	60	406	68	80	24.0	27.5	162	27.1	G	1.2
4RC200M2-43	4RCX200M2-43	20	460	3	60	203	34	40	24.0	27.5	162	27.1	z	1.2
4RC200M2-53	4RCX200M2-53	20	575	3	60	162	27.2	32	24.0	27.5	162	27.1	G	1.2
4RC250M2-23	4RCX250M2-23	25	230	3	60	406	83	96	28.6	32.5	162	33.1	G	1.2
4RC250M2-43	4RCX250M2-43	25	460	3	60	203	41.5	48	28.6	32.5	162	33.1	G	1.2
4RC250M2-53	4RCX250M2-53	25	575	3	60	162	33.2	38.4	28.6	32.5	162	33.1	G	1.2
4RC300M2-23	4RCX300M2-23	30	230	3	60	406	95	115	33.4	38.6	162	37.8	G	1.2
4RC300M2-43	4RCX300M2-43	30	460	3	60	203	47.5	57.5	33.4	38.6	162	37.8	G	1.2
4RC300M2-53	4RCX300M2-53	30	575	3	60	162	38	46	33.4	38.6	162	37.8	G	1.2
4RC400M2-43	4RCX400M2-43	40	460	3	60	275	59	70	42.0	49.5	217	47.0	G	1.2
4RC400M2-53	4RCX400M2-53	40	575	3	60	220	47.2	56	42.0	49.5	217	47.0	G	1.2
4RC500M2-43	4RCX500M2-43	50	460	3	60	275	74	89	51.0	61.0	217	58.9	D	1.2
4RC500M2-53	4RCX500M2-53	50	575	3	60	220	59.2	71.2	51.0	61.0	217	58.9	D	1.2
4RC600M2-43	4RCX600M2-43	60	460	3	60	275	89	89	61.0	61.0	217	70.8	C	1.0
4RC600M2-53	4RCX600M2-53	60	575	3	60	220	71.2	71.2	61.0	61.0	217	70.8	C	1.0

Motor Efficiencies and Power Factor									
HP	Phase	Motor Efficiency %				Power Factor %			
		Service Factor Load	100% Load	75% Load	50% Load	Service Factor Load	100% Load	75% Load	50% Load
20	3	65	63	58	50	83.5	83	82	80
25	3	67	66	61	54	85	85	84.5	82
30	3	71	70	66	60	86	86.5	86	84
40	3	75.5	75	72	66	86.6	87.7	87.5	86
50	3	75	75.4	74.3	69.5	84.6	86.8	87.8	87.5
60	3	75	75	75.5	72	84.6	84.6	87.5	87.7

PUMP MODEL — Pump shall be Myers Model Numbers 4RC/4RCX Non-Clog Submersible Pump with recessed type impeller. All openings in pump shall be large enough to pass a 3" diameter sphere. Discharge flange shall be four (4) inch standard. The pump and motor assembly shall be FM listed for Class 1, Groups C and D explosion-proof service (4RCX only).

OPERATING CONDITIONS — Pump shall have a capacity of _____ GPM at a total head of _____ feet and shall use a _____ HP motor operating at _____ RPM.

MOTOR — Pump motor shall be of the sealed submersible type rated _____ HP at _____ RPM, 60 Hertz. Motor shall be for three phase 200 volts _____, 230 volts _____, 460 volts _____ or 575 volts _____. Motor shall be NEMA B type.

Stator winding shall be of the open type with Class H insulation good for 180°C (356°F) maximum operating temperature. Winding housing shall be filled with a clean high dielectric oil that lubricates bearings and seals and transfers heat from windings and rotor to outer shell. Air-filled motors that do not have the superior heat dissipating capabilities of oil-filled motors shall not be considered equal.

Motor shall have two heavy duty ball bearings to support pump shaft and take radial and thrust loads and a sleeve guide bushing directly above the lower seal to take radial load and act as flame path for seal chamber. Ball bearings shall be designed for 50,000 hours B-10 life. Stator shall be heat shrunk into motor housing.

A heat sensor thermostat shall be attached to and imbedded in the winding and be connected in series with the motor starter contactor coil to stop motor if temperature of winding is more than 302°F. Thermostat to reset automatically when motor cools to safe operating temperature. Three heat sensors to be used on 3 phase motors. The common pump motor shaft shall be of 416 stainless steel.

SEALS — Motor shall be protected by two mechanical seals mounted in tandem with a seal chamber between the seals. Seal chamber shall be oil filled to lubricate seal face and to transmit heat from shaft to outer shell.

Seal face shall be carbon and ceramic and lapped to a flatness of one light band. Lower seal faces shall be _____ carbide (optional).

A double electrode shall be mounted in the seal chamber to detect any water entering the chamber through the lower seal. Water in the chamber shall cause a red light to turn on at the control box. This signal shall not stop the motor but shall act as a warning only, indicating service is required.

IMPELLER — The impeller shall be ductile iron and of the recessed type. Pump-out vanes shall be used on back shroud. Impeller shall be dynamically balanced. Impeller shall be driven by stainless steel key and impeller held in position with lock screw and washer.

Impeller and motor shall have top lift-out of case so that the assembly can be removed without disturbing any piping.

PUMP CASE — The volute case shall be cast iron and have a flanged center line discharge. Discharge flange shall be 4" standard with bold holes straddling center line. The pump case shall have a minimum of 3" diameter openings to allow for free passage of a 3" diameter spherical solid.

PUMP AND MOTOR CASTING — All castings shall be of high tensile cast iron and shall be treated with phosphate and chromate rinse. All fasteners shall be 302 stainless steel.

BEARING END CAP — Upper motor bearing cap shall be a separate casting for easy mounting and replacement.

POWER CABLES — Power cord and control cord shall be triple sealed. The power and control conductor shall be single strand sealed with epoxy potting compound and then clamped in place with rubber seal bushing to seal outer jacket against leakage and to provide for strain pull. A third sealing area shall be provided by a terminal board to separate the cable entry chamber from the motor chamber. Cords shall withstand a pull of 300 pounds.

Insulation of power and control cords shall be type SO or SOOW. Both control and power cords shall have a green carrier ground conductor that attaches to motor frame.



1101 Myers Parkway
Ashland, Ohio 44805

Tel: (419) 289-1144
Fax: (419) 281-9980

269 Trillium Drive
Kitchener, Ontario
Canada N2G 4W5

Tel: (519) 748-5470
Fax: (519) 748-2553

www.femyers.com