

WG30H-75H and WGX30H-75H

Standard (WG30H-75H) and Explosion-proof (WGX30H-75H)
3-7½ HP, High Head Submersible Grinder Pumps



30H-75H only)

MYERS WG30H-75H ARE RUGGED 3-7½ HORSEPOWER SUBMERSIBLE CENTRIFUGAL GRINDER PUMPS DESIGNED FOR RESIDENTIAL, COMMERCIAL OR INDUSTRIAL APPLICATIONS. They are especially suited for use in pressure sewer applications or in systems with long discharge runs or high static heads. The WG30H-75H feature a heavy duty cutter mechanism and recessed impeller design to efficiently grind typical sewage solids into a fine slurry.

The WG30H-75H grinder pumps are available in standard and U.L. Listed explosion-proof (WGX30H-75H), construction for use in Class 1, Group D hazardous locations.

WG30H-75H grinder pumps can be installed in a variety of packaged systems. Factory-assembled simplex or duplex packages with guide rail systems are available. Individual rail components are also available for installation in onsite concrete systems. F.E. Myers offers a complete line of submersible sump, sewage, effluent, grinder, non-clog wastewater pumps, controls, basins and accessories. For additional information, please contact your local Myers representative or the Myers Ohio sales office at 419-281-1144.

ADVANTAGES BY DESIGN

IDEAL FOR USE IN PRESSURE SEWER SYSTEMS

- Recessed impeller provides steep non-overloading operating curve.

DURABLE MOTOR WILL DELIVER MANY YEARS OF RELIABLE SERVICE.

- Oil-filled motor for maximum heat dissipation and constant bearing lubrication.
- Recessed impeller reduces radial bearing loads, increases bearing life.
- High torque capacitor start/run single phase or three phase motors for assured starting under heavy load.
- Seal leak probes and on-winding heat sensors warn of seal leak condition, and stop motor if motor overheats. Helps prevent costly motor damage.

THE WG30H-75H SERIES IS DESIGNED FOR EASY MAINTENANCE.

- Shredding ring and grinder impeller are replaceable without dismantling pump or motor.

PRODUCT CAPABILITIES

Capacities To	98 gpm	367 lpm
Heads To	170 ft.	52.0 m
Liquids Handling	domestic raw sewage	
Intermittent Liquid Temp.	up to 140° F	up to 60° C
Winding Insulation Temp. (Class F)	311°F	155°C
Motor Electrical Data (Single phase motors are capacitor start type. Myers control panels or capacitor kits are recommended for proper operation and warranty.)	3450 rpm, 60 Hz 3-5 hp, 230V, 1Ø 3-7½ hp, 200, 230, 460V, 3Ø	
Third Party Approvals	CSA	
Optional Approvals	UL Class 1, Group D (WGX30H-75H)	
Acceptable pH Range	6 - 9	
Specific Gravity	.9 - 1.1	
Viscosity	28 - 35 SSU	
Discharge, NPT	2½ in.	63.5 mm
Min. Sump Diameter		
Simplex	36 in.	91.4 cm
Duplex	48 in.	121.9 cm

Note: Consult factory for applications outside of these recommendations.

Construction Materials

Motor Housing, Seal Housing, Cord Cap, Volute Case	cast iron, Class 30, ASTM A48
Impeller	recessed, bronze
Power and Control Cords	25 ft. SOOW
Mechanical Seals - Std. Opt.	dbl. tandem carbon & ceramic lower tungsten carbide
Pump, Motor Shaft	416 SST
Fasteners	300 Series SST
Shredding Ring and Grinder Impeller	440 SST, 58-60 Rockwell

WHERE INNOVATION MEETS TRADITION

Myers®

Pentair Water

STATOR

3450 RPM, 1 and 3 phase. Press fit for perfect alignment and best heat transfer. Oil-filled motor conducts heat and lubricates bearings.

CABLE ENTRY SYSTEM

Provides double seal protection. Cable jacket sealed by compression grommet. Individual wires sealed by epoxy potting.

HEAT SENSOR

Protects motor from burn-out due to excessive heat from any overload condition. Automatically resets when motor has cooled.

BALL BEARINGS

Upper and lower ball bearings support shaft and rotor and take axial and radial loads.

HEAVY 416 SST SHAFT

Corrosion resistant. Reduces shaft deflection due to grinding loads.

SHAFT SEALS

Double tandem mechanical shaft seals protect motor. Oil-filled seal chamber provides continuous lubrication.

SLEEVE BEARING

Takes radial load; provides flame path. (UL Listed pumps only.)

SEAL LEAK PROBE

Detects water in seal housing, activates warning light in control panel. (Test resistor on UL Listed models.)

VOLUTE CASE

Cast iron, horizontal discharge. (Drilled for 2 1/2" pipe flange.)

GRINDER ASSEMBLY

Grinder impeller and shredding ring are replaceable without dismantling pump. Constructed of 440 SST hardened to 56-60 Rockwell.

IMPELLER

Bronze recessed impeller handles ground slurry without clogging or binding. Provides unobstructed flow passage. Reduces radial loads. Pump-out vanes help keep trash from seal, reduces pressure at seal faces.

DIMENSIONS

(Dimensions in MM)

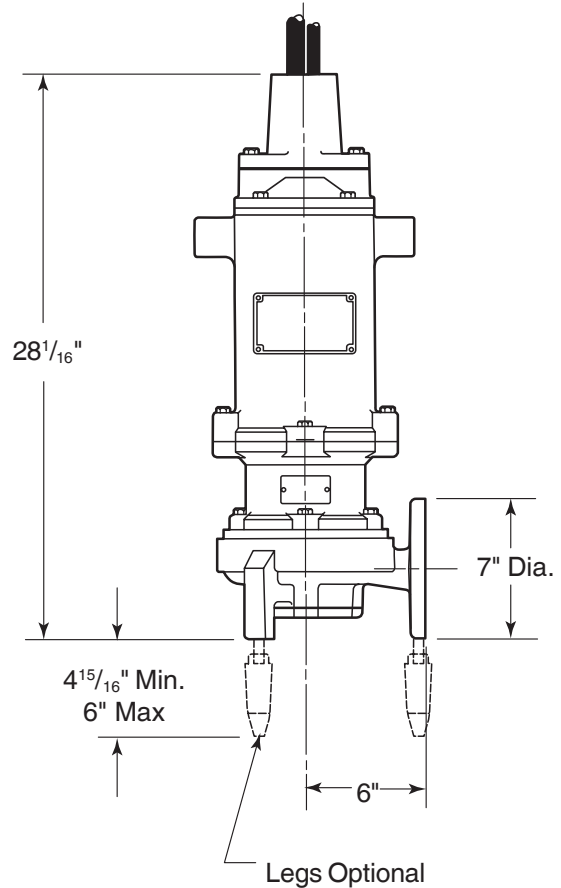
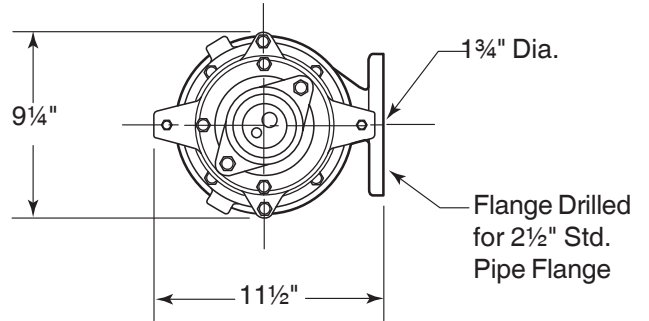

PUMP PERFORMANCE

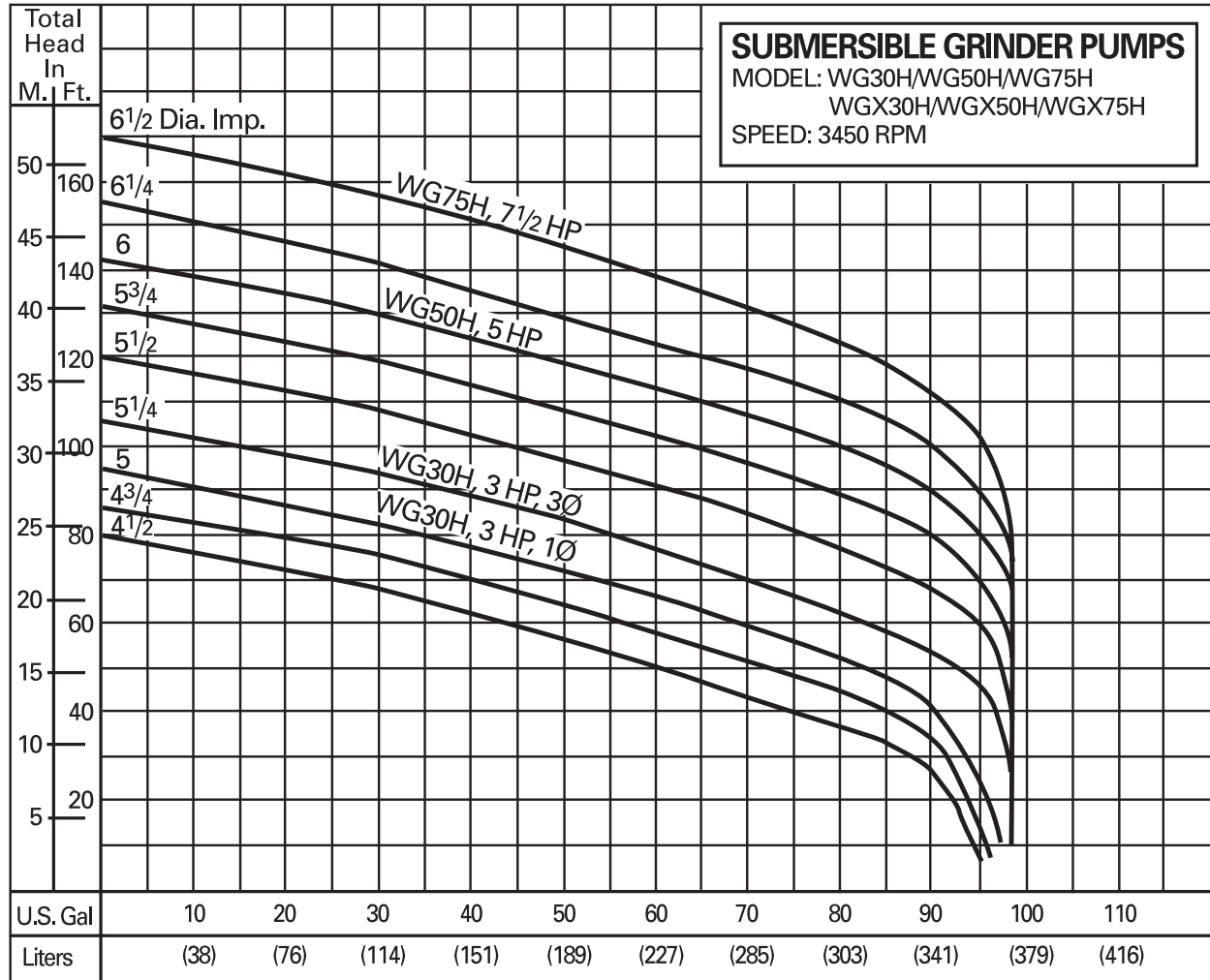

Available Models		Motor Electrical Data										
Standard	Explosion Proof	HP	Volts	Phase	Hertz	Start Amps	Run Amps	Run KW	Start KVA	Run KVA	NEC Code Letter	Service Factor
WG30H-21-25	WGX30H-21-25	3	230	1	60	82	21.0	4.3	41.9	4.8	G	1.4
WG30H-03-25	WGX30H-03-25	3	200	3	60	69	15.0	4.3	23.9	5.2	J	1.4
WG30H-23-25	WGX30H-23-25	3	230	3	60	53	13.0	4.3	21.1	5.2	H	1.4
WG30H-43-25	WGX30H-43-25	3	460	3	60	26	6.5	4.3	20.7	5.2	H	1.4
WG30H-53-25	WGX30H-53-25	3	575	3	60	21	5.2	4.3	21.0	5.2	H	1.4
WG50H-21-25	WGX50H-21-25	5	230	1	60	122	32	6.3	28.1	7.4	G	1.7
WG50H-03-25	WGX50H-03-25	5	200	3	60	90	21.6	6.3	31.1	7.5	G	1.7
WG50H-23-25	WGX50H-23-25	5	230	3	60	78	18.8	6.3	27.0	7.5	G	1.7
WG50H-43-25	WGX50H-43-25	5	460	3	60	39	9.4	6.3	31.0	7.5	G	1.7
WG50H-53-25	WGX50H-53-25	5	575	3	60	31	7.5	6.3	31.0	7.5	G	1.7
WG75H-03-25	WGX75H-03-25	7.5	200	3	60	90	25.8	7.9	31.1	8.9	D	1.15
WG75H-23-25	WGX75H-23-25	7.5	230	3	60	78	22.4	7.9	27.0	8.9	D	1.15
WG75H-43-25	WGX75H-43-25	7.5	460	3	60	39	11.2	7.9	31.0	8.9	D	1.15
WG75H-53-25	WGX75H-53-25	7.5	575	3	60	31	9.0	7.9	31.0	8.9	D	1.15

WG30H-75H and WGX30H-75H

SPECIFICATIONS

PUMP MODEL - Pump shall be of the centrifugal type Myers model _____ or equal with an integrally built in grinder unit and submersible type motor. The grinder unit shall be capable of macerating all material in normal domestic and commercial sewage including reasonable amounts of foreign objects such as small wood, sticks, plastic, thin rubber, sanitary napkins, disposable diapers and the like to a fine slurry that will pass freely through the pump and 2" discharge pipe. Discharge shall be standard 2½" flange. Pump and motor assembly shall be UL listed for Class 1, Group D explosion-proof service (WG30H - 75H only).

OPERATING CONDITIONS - Pump shall have a capacity of _____ GPM at a total head of _____ feet and shall use a _____ HP motor operating at 3450 RPM.

MOTOR - Pump motor shall be of the totally enclosed, submersible, squirrel cage induction type rated _____ horsepower at 3450 RPM, 60 Hz.

Motor shall be for single phase 230 volts _____ or three phase 200 volts _____, 230 volts _____, 460 volts _____, or 575 volts _____. Single phase motors shall be of capacitor start, capacitor run, NEMA L type. Three phase motors shall be NEMA B type.

Stator winding shall be of the open type with Class F insulation good for 155°C (311°F) maximum operating temperature. Winding housing shall be filled with a clean high dielectric oil that lubricates bearings and seals and transfers heat from windings and rotor to outer shell. Air-filled motors which do not have the superior heat dissipating capabilities of oil-filled motors shall not be considered equal.

Motor shall have two heavy duty ball bearings to support pump shaft and take radial and thrust loads and a sleeve guide bushing directly above the lower seal to take radial load and act as flame path for seal chamber. Ball bearings shall be designed for 50,000 hours B-10 life. Stator shall be heat shrunk into motor housing.

A heat sensor thermostat shall be attached to top end of motor winding and shall be connected in series with the magnetic contactor coil in control box to stop motor if motor winding temperature reaches 221°F. Thermostat to reset automatically when motor cools. Three heat sensors shall be used on 3 phase motors.

The common motor pump and grinder shaft shall be of #416 stainless steel threaded to take pump impeller and grinder impeller.

SEALS - Motor shall be protected by two mechanical seals mounted in tandem with a seal chamber between the seals. Seal chamber shall be oil filled to lubricate seal face and to transmit heat from shaft to outer shell.

Seal face shall be carbon and ceramic and lapped to a flatness of one light band. Lower seal faces shall be _____ carbide (optional).

A double electrode shall be mounted in the seal chamber to detect any water entering the chamber through the lower seal. Water in the chamber shall cause a red light to turn on at the control box. This signal shall not stop motor but shall act as a warning only, indicating service is required.

PUMP IMPELLER - The pump impeller shall be of the recessed Myers type to provide an open unobstructed passage through the volute for the ground solids. Impeller shall be of 85-5-5-5 bronze and shall be threaded onto stainless steel shaft. Enclosed or semi-open pump impellers which might become obstructed during grinding or add excessive radial loads shall not be considered as equal.

GRINDER CONSTRUCTION - Grinder assembly shall consist of a single rotating grinder impeller and a single stationary shredding ring mounted directly below pump volute inlet. Grinder impeller shall thread onto shaft and shall be locked with a screw and washer. Shredding ring shall be held in place by a steel retaining clamp. Both shredding ring and grinder impeller shall be removable without dismantling pump. No adjustment of grinder assembly shall be necessary for proper grinder operation. Multiple grinder impeller assemblies requiring initial or periodic axial adjustment for proper operation shall not be considered equal. Grinder impeller and shredding ring shall be made of 440C stainless steel hardened to 58-60 Rockwell.

CORROSION PROTECTION - All iron castings shall be pretreated with phosphate and chromic rinse and to be painted before machining and all machined surfaces exposed to the sewage water to be repainted. All fasteners to be 302 stainless steel.

BEARING END CAP - Upper motor bearing cap shall be a separate casting for easy mounting and replacement.

POWER CABLES - Power cord and control cord shall be double sealed. The power and control conductor shall be single strand sealed with epoxy potting compound and then clamped in place with rubber seal bushing to seal outer jacket against leakage and to provide for strain pull. Cords shall withstand a pull of 300 pounds to meet U.L. requirements.

Insulation of power and control cords shall be type SOOW. Both control and power cords shall have a green carrier ground conductor that attaches to motor frame.