



## Pressure Snubber with Choke Valve

### APPLICATIONS:

- Pulsation application
- Heavy duty process applications
- Industrial applications

### FEATURES:

- Adjustable Pressure Pulsation Dampener protects pressure gauges against pressure perturbation, surges and fluid hampers
- Isolates gauge for service or replacement



### PRESSURE RANGES:

- 0-20 In.WC to 0-500 PSI  
(see ordering guide.)

### ACCURACY:

- Based on part number  
Ranges from 3,000 to 10,000 PSI

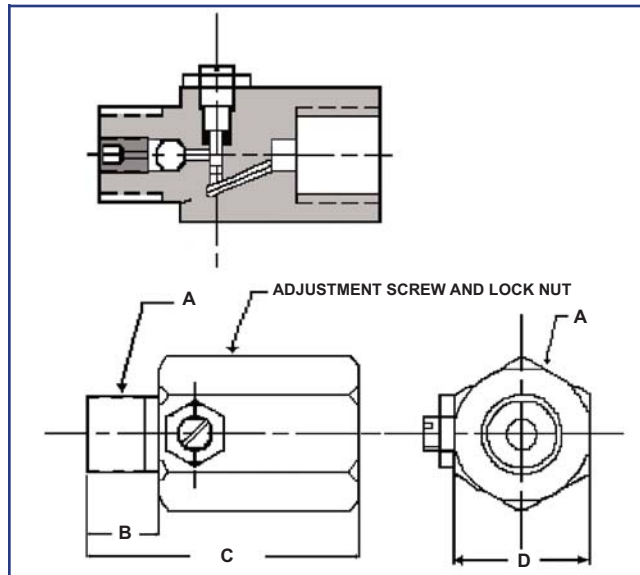

PART #	"A" THD. SIZE	"B"	"C"	"D" HEX	MAXIMUM PRESSURE
<b>MSB4</b>	1/4-18NPT	.51 (13MM)	1.77 (45MM)	.67 (17MM)	3,000 PSI
<b>MSS4</b>	1/4-18NPT	.51 (13MM)	1.77 (45MM)	.67 (17MM)	5,000 PSI
<b>MSB6</b>	3/8-18NPT	.59 (16MM)	2.36 (60MM)	1.18 (30MM)	5,000 PSI
<b>MSS6</b>	3/8-18NPT	.59 (16MM)	2.36 (60MM)	1.18 (30MM)	10,000 PSI
<b>MSB8</b>	1/2-1/4-NPT	.79 (20MM)	2.36 (60MM)	1.18 (30MM)	5,000 PSI
<b>MSS8</b>	1/2-1/4-NPT	.79 (20MM)	2.36 (60MM)	1.18 (30MM)	10,000 PSI

Blue Ribbon reserves the right to make product improvements and amendments to the product specifications stated throughout this brochure without prior notification. Please contact the factory on all critical dimensions and specifications for verification.

A5BR-B4.00

2770 Long Road, Grand Island, NY 14072 USA

Tel. (716) 773-9300 • Fax (716) 773-5019 • brsales@blueribboncorp.com • www.blueribboncorp.com